

**Modular Cooking Range Line
EVO900 400mm Gas Fry Top,
Smooth Brushed Chrome Horizontal
Plate**

ITEM # _____

MODEL # _____

NAME # _____

SIS # _____

AIA # _____



392402 (Z9IINAOMCA)

Half module gas fry top with smooth brushed chrome cooking plate, horizontal, thermostatic control, scraper and stopper included

Short Form Specification**Item No.** _____

Smooth cooking surface in brushed chrome. 10 kW gas powered burners with thermostatic valve and self stabilizing flame. Temperature range up to 270°C. To be installed on open base installations, bridging supports or cantilever systems. Removable drawer below the cooking surface for the collection of grease and fat. Body and work top of unit entirely in stainless steel with Scotch Brite finish. Extra strength work top in heavy duty 2 mm stainless steel. Right-angled side edges to allow flush-fitting junction between units.

Main Features

- Unit to be mounted on open base cupboards, bridging supports or cantilever systems.
- Large drain hole on cooking surface permits the draining of fat into large 1 liter collector placed under the cooking surface.
- Stainless steel high splash guards on the rear and sides of cooking surface. Splash guards can be easily removed for cleaning and are dishwasher-safe.
- Piezo spark ignition with thermostatic valve for added safety.
- The special design of the control knob system guarantees against water infiltration.
- IPX5 water protection.
- Temperature range from 90° up to 270°C.
- Rough brushed chrome surface is highly resistant to scratches and facilitates cleaning operations at the end of the day.
- Scraper for smooth plate included as standard.
- Suitable for countertop installation.

Construction

- All exterior panels in Stainless Steel with Scotch Brite finishing.
- AISI 304 stainless steel worktop, 2mm thick.
- Model has right-angled side edges to allow flush fitting joints between units, eliminating gaps and possible dirt traps.
- Unit is 900mm deep to give a larger working surface area.
- Cooking surface 15mm thick brushed chrome for optimum grilling results and ease of use.
- Cooking surface completely smooth.

APPROVAL: _____

Included Accessories

- 1 of Scraper for smooth plate for fry tops PNC 164255
- 1 of Stopper for fry top horizontal plate PNC 206296

Optional Accessories

- Scraper for smooth plate for fry tops PNC 164255
- Junction sealing kit PNC 206086
- Draught diverter, 120 mm diameter PNC 206126
- Matching ring for flue condenser, 120 -130 mm diameter PNC 206127
- Support for bridge type installation, 800 mm PNC 206137
- Support for bridge type installation, 1000 mm PNC 206138
- Support for bridge type installation, 1200 mm PNC 206139
- Support for bridge type installation, 1400 mm PNC 206140
- Support for bridge type installation, 1600 mm PNC 206141
- Water drain for half module fry top PNC 206153
- Support for bridge type installation, 400 mm PNC 206154
- Side handrail for right/left hand PNC 206165
- Frontal handrail 400 mm PNC 206166
- Frontal handrail 800 mm PNC 206167
- Large handrail (portioning shelf) 400 mm PNC 206185
- Large handrail (portioning shelf) 800 mm PNC 206186
- Frontal handrail 1200 mm PNC 206191
- Frontal handrail 1600 mm PNC 206192
- Stopper for fry top horizontal plate PNC 206296
- Flue condenser for 1/2 module, 120 mm diameter PNC 206310
- 2 side covering panels, height 250 mm, depth 900 mm PNC 206321
- Grease/oil container kit for frytops PNC 206346
- Chimney grid net, 400mm PNC 206400
- - NOT TRANSLATED - PNC 206455
- KIT G.25.3 (NL) GAS NOZZLES FOR 900 FRYERS PNC 206467
- Pressure regulator for gas units PNC 927225

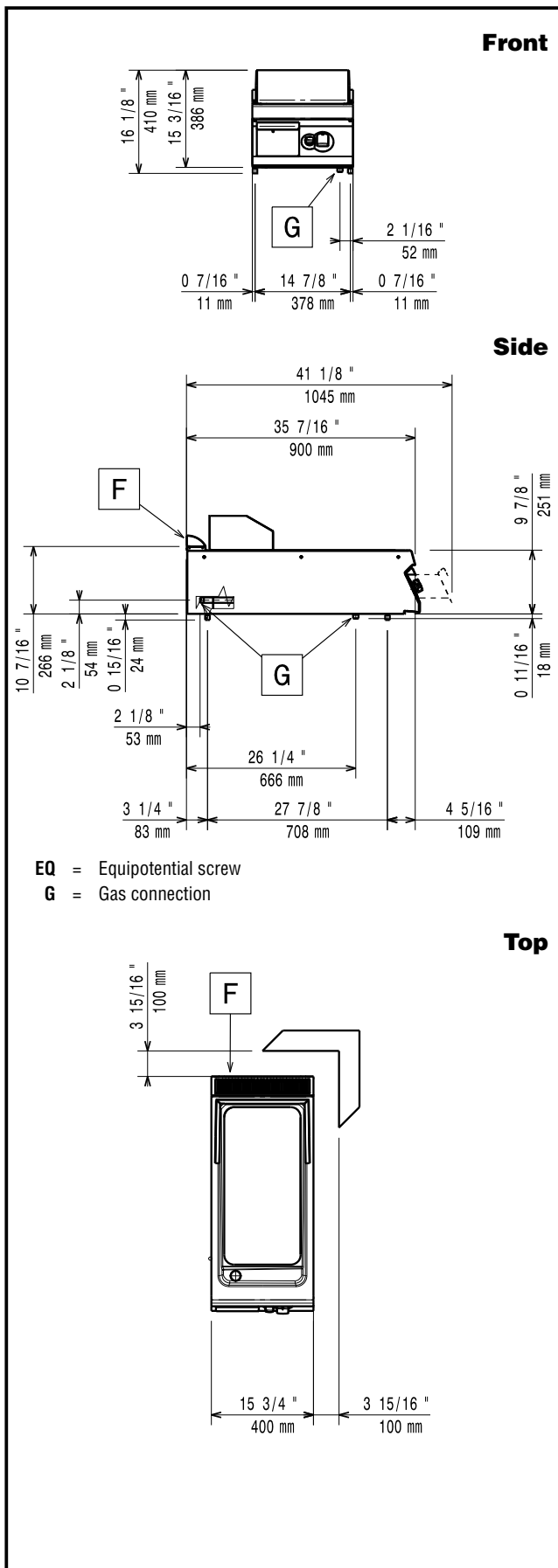

Gas

Gas Power:	10 kW
Standard gas delivery:	Natural Gas G20 (20mbar)
Gas Type Option:	LPG; Natural Gas
Gas Inlet:	1/2"

Key Information:

Working Temperature MIN:	90 °C
Working Temperature MAX:	270 °C
External dimensions, Width:	400 mm
External dimensions, Depth:	900 mm
External dimensions, Height:	250 mm
Net weight:	55 kg
Shipping weight:	58 kg
Shipping height:	580 mm
Shipping width:	460 mm
Shipping depth:	1020 mm
Shipping volume:	0.27 m ³
Cooking surface width:	330 mm
Cooking surface depth:	700 mm

If appliance is set up or next to or against temperature sensitive furniture or similar, a safety gap of approximately 150 mm should be maintained or some form of heat insulation fitted.